

GENERAL DIMENSIONS

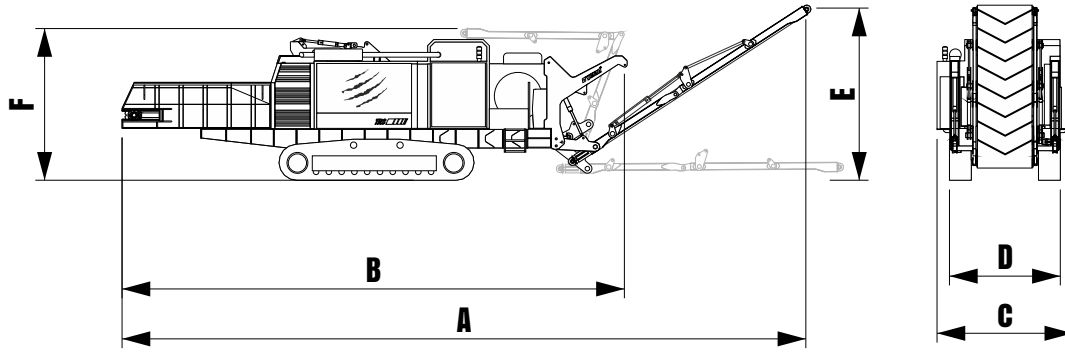

	A	B	C	D	E	F
DIMENSIONS (MM)	15700	11500	3110	2540	3890	3450

Engine

400 Kw 6 Cylinder 12,5 Lt
Emission Standard: STAGE IIIA or STAGE IV

Transmission

PLC adapted
Hydraulic torque converter transmission

Hydraulic System

Variable displacement axial piston pump
Proportional controlled hydraulic valve block

Undercarriage

Double displacement and two stage speed
hydro-motor driven steel undercarriage

Automation

Fully automation with PLC
7" Control Screen
Remote Control System

Total Weight

36.000 KG

Product Conveyor

Hydraulic gerotor motor ve planetary reducer
drived drag chain conveyor
Infeed opening: 850x1500mm

Transfer Conveyor

Hydraulic gerotor motor ve planetary reducer
drived belt conveyor

Infeed

Charging drum Diameter: 850 mm
Belt-pulley driven rotor
Various screen options
Various blade types options
Rotor Diameter: 1100mm

TECHNICAL SPECIFICATIONS



Max. Wood Diameter

600 mm



Load Height

2200 mm